

# CK25

# CALANDRA RACING CONCEPTS SETUP SHEET

Driver: \_\_\_\_\_  
 Date: \_\_\_\_\_  
 Event: \_\_\_\_\_  
 Track: \_\_\_\_\_  
 Result: \_\_\_\_\_

### Track Conditions

- CRC Black     CRC Grey     ETS  
 \_\_\_\_\_  
 Low             Medium        High  
 Small            Medium        Large  
 Smooth         Both            Bumpy  
 Temp: \_\_\_\_\_ Humidity: \_\_\_\_\_

### Shock

Oil: \_\_\_\_\_  
 Spring: \_\_\_\_\_  
 Length: \_\_\_\_\_  
 Preload: \_\_\_\_\_

### Damper Tube

- 5k    10k    15k    20k  
 \_\_\_\_\_

### Front Tires

Compound: \_\_\_\_\_  
 Diameter: \_\_\_\_\_  
 Additive: \_\_\_\_\_  
 Soak time: \_\_\_\_\_

### Rear Tires

Compound: \_\_\_\_\_  
 Diameter: \_\_\_\_\_  
 Additive: \_\_\_\_\_  
 Soak time: \_\_\_\_\_

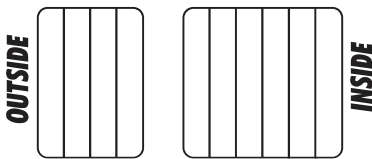

### Electronics

Motor: \_\_\_\_\_  
 Timing: \_\_\_\_\_  
 Battery: \_\_\_\_\_  
 ESC: \_\_\_\_\_  
 Ratio: \_\_\_\_\_

### Aerodynamics

Body: \_\_\_\_\_  
 Position: \_\_\_\_\_  
 Car weight: \_\_\_\_\_

Suspended Pod: \_\_\_\_\_  
 (Shock lenght)

Race Ready Pod: \_\_\_\_\_  
 (Shock Preload)

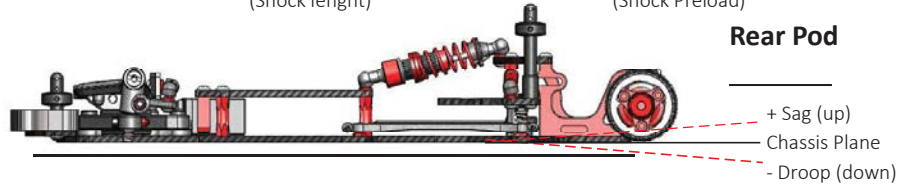

Ride Height - Front: \_\_\_\_\_ Middle: \_\_\_\_\_ Rear: \_\_\_\_\_

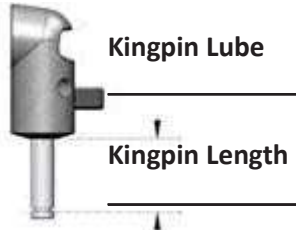

Kingpin Lube \_\_\_\_\_  
 Kingpin Length \_\_\_\_\_  
 Front Spring  
 45    50    55    60  
 \_\_\_\_\_

Dynamic Caster Block  
 0°    5°    10°



Caster  
 3 shims front  
 2 shims front  
 1 shim front  
 All shims back

Camber: \_\_\_\_\_



Roll Center Spacer  
 0mm  
 2mm  
 2.5mm

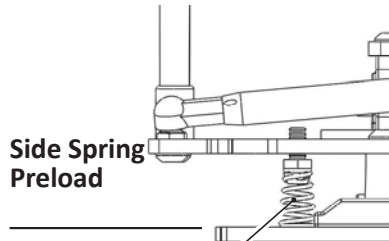

Side Spring Preload  
 Side Spring  
 45    50    55    60  
 \_\_\_\_\_

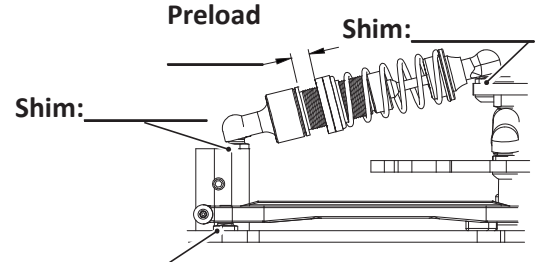

Rear Steer - Shim: \_\_\_\_\_

Battery Position

- Forward  
 Rearward  
 \_\_\_\_\_

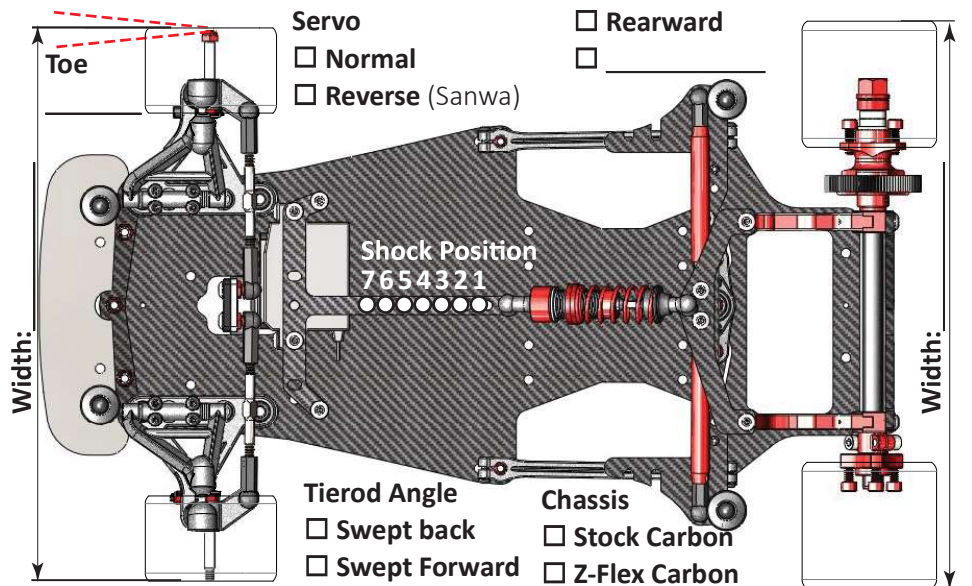

Front Brace:  Yes    No

Servo  
 Normal  
 Reverse (Sanwa)  
 Tierod Angle  
 Swept back  
 Swept Forward  
 Straight

Chassis  
 Stock Carbon  
 Z-Flex Carbon  
 Aluminium