

Fenix

G12-2

Rev. 0.0.2

January 2024



G12-2 is an high-competition, high-quality, 1/12-scale model car intended for persons aged 16 years and older with previous experience building and operating RC model racing cars. This is not a toy; it is a precision racing model. This model racing car is not

Fenix G12-2

intended for use by beginners, inexperienced customers, or inexperienced racers or by children without direct supervision of a responsible, knowledgeable adult.

Before building and operating your G12-2, YOU MUST read through all of the operating instructions and instruction manual and fully understand them to get the maximum enjoyment and prevent unnecessary damage. Read carefully and fully understand the instructions before beginning assembly.

Contents of the box may differ from pictures. In line with our policy of continuous product development, the exact specifications of the kit may vary without prior notice.

Take appropriate safety precautions prior to operating this model. You are responsible for this model's assembly and safe operation! Please read the instruction manual before building and operating this model and follow all safety precautions

IMPORTANT NOTES – GENERAL

- This product is not suitable for children under 16 years of age without the direct supervision of a responsible and knowledgeable adult.
- Carefully read all manufacturers warnings and cautions for any parts used in the construction and use of your model.
- Assemble this kit only in places away from the reach of very small children.
- First-time builders and users should seek advice from people who have building experience in order to assemble the model correctly and to allow the model to reach its performance potential.
- Exercise care when using tools and sharp instruments.
- Take care when building, as some parts may have sharp edges.
- Keep small parts out of reach of small children. Children must not be allowed to put any parts in their mouth, or pull vinyl bag over their head.
- Read and follow instructions supplied with paints and/or cement, if used (not included in kit).
- Immediately after using your model, do NOT touch equipment on the model such as the motor and speed controller, because they generate high temperatures. You may seriously burn yourself seriously touching them.
- Follow the operating instructions for the radio equipment at all times.
- Do not put fingers or any objects inside rotating and moving parts, as this may cause damage or serious injury as your finger, hair, clothes, etc. may get caught.
- Be sure that your operating frequency is clear before turning on or running your model, and never share the same frequency with somebody else at the same time. Ensure that others are aware of the operating frequency you are using and when you are using it.
- Use a transmitter designed for ground use with RC cars. Make sure that no one else is using the same frequency as yours in your operating area. Using the same frequency at the same time, whether it is driving, flying or sailing, can cause loss of control of the RC model, resulting in a serious accident.
- Always turn on your transmitter before you turn on the receiver in the car. Always turn off the receiver before turning your transmitter off.
- Keep the wheels of the model off the ground when checking the operation of the radio equipment.
- Disconnect the battery pack before storing your model.
- When learning to operate your model, go to an area that has no obstacles that can damage your model if your model suffers a collision.
- Remove any sand, mud, dirt, grass or water before putting your model away.
- If the model behaves strangely, immediately stop the model, check and clear the problem.
- To prevent any serious personal injury and/or damage to property, be responsible when operating all remote controlled models.
- The model car is not intended for use on public places and roads or areas where its operation can conflict with or disrupt pedestrian or vehicular traffic.
- Because the model car is controlled by radio, it is subject to radio interference from many sources that are beyond your control. Since radio interference can cause momentary loss of control, always allow a safety margin in all directions around the model in order to prevent collisions.
- Do not use your model:
 - Near real cars, animals, or people that are unaware that an RC car is being driven.
 - In places where children and people gather
 - In residential districts and parks
 - In limited indoor spaces
 - In wet conditions
 - In the street
 - In areas where loud noises can disturb others, such as hospitals and residential areas.
 - At night or anytime your line of sight to the model may be obstructed or impaired in any way.

To prevent any serious personal injury and/or damage to property, please be responsible when operating all remote controlled models.

Failure to follow these instructions will be considered as abuse and/or neglect.

We have made every effort to make these instructions as easy to understand as possible.

However, if you have any difficulties, problems, or questions, please do not hesitate to contact the Fenix support team at racing@fenixwaterjet.com . Also, please visit our Web site

at www.Fenix-racing.com or www.fenixracingshop.com or <https://www.facebook.com/FenixRacing.it/>

the latest updates, set-up information, option parts, and many other goodies. We pride ourselves on taking excellent care of our customers.

Just a quick note.... Read the manual "before" and not after....

Carbon Nut assembly

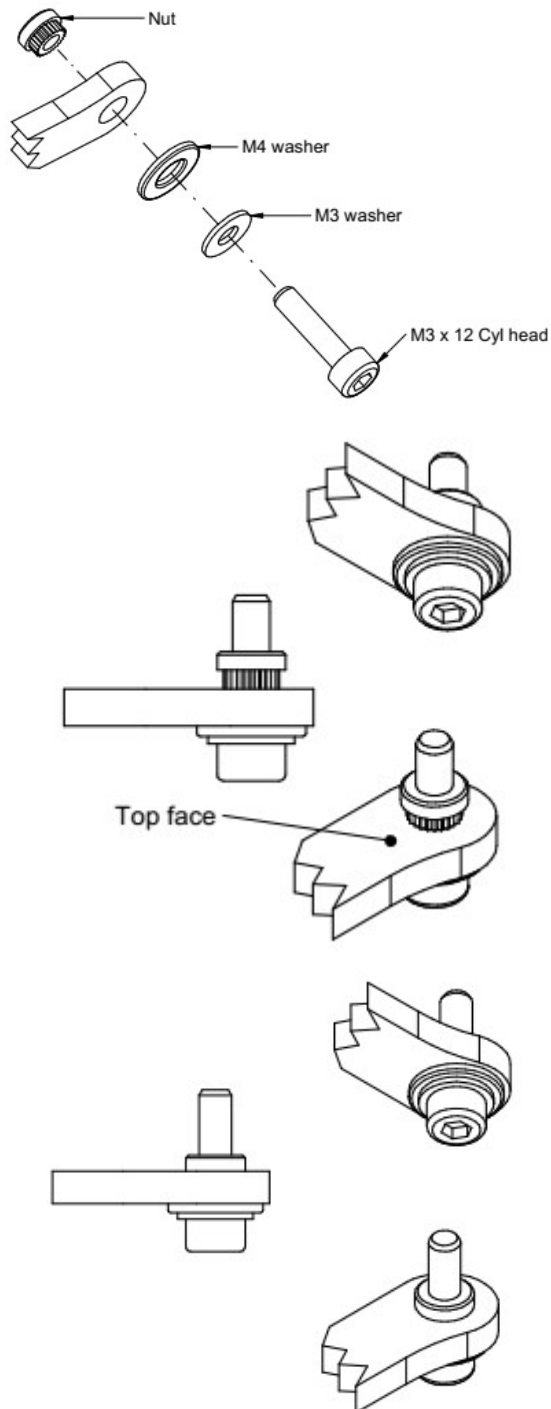

----- **Read me first!!!** -----

G12.2 use this kind of special nut in several places. Just take your time and the result will be great.

Those comes already pre-assembled, but is always good to know “how to”, just in case of...

To insert the Nut in the carbon fibre you have to follow this easy procedure.

Slide the M3 and M4 washer over the M3 x 12 Socket Head Screw.

Insert the screw in the carbon part and tight by hand the special nut.

Once the nut hit the carbon fibre it will start to secure itself into the CF.

Tighten it slowly (very slowly) until it stops.

Don't overtight it – is completely unnecessary

Tip 1:

You might want to slightly chamfer the Top face with your body reamer. Just enough to remove the sharp edge

Tip 2:

When the nut hit the carbon fibre, before insert it fully, you can add a tiny drop of thin slow cure CA glue. *Very tiny....*

Tip 3:

Don't use electric tools to drive the screw, most likely you'll end damaging the carbon fibre....

Fenix G12-2

Bag A

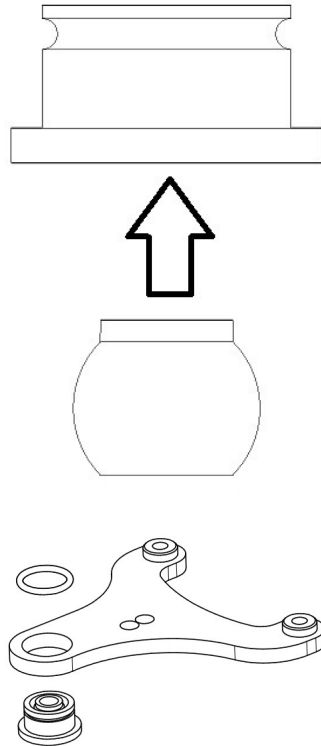

Note: Be sure that the sphere holder fit easily, you might have to enlarge the hole with some sandpaper.

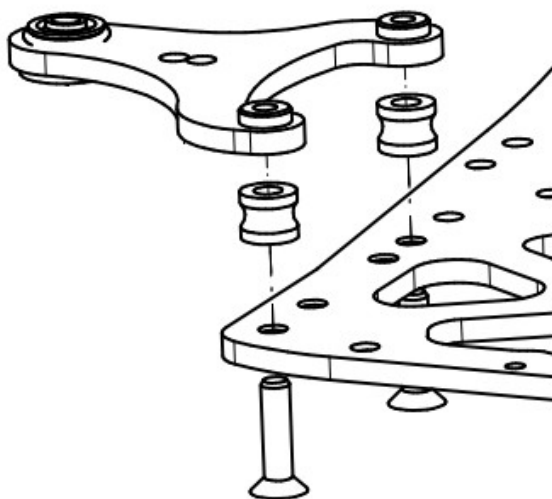

Front End

2 x G56038 Sphere holder
2 x M20-K3 6mm sphere

Make 2 sets

Insert the group into the G562-11 front arm -

Fix the sphere holder with the provided O-ring

Make 2 mirror sets.

Insert the OPT-038 Oring around the sphere holder.

Insert 2 HW026 M3x12 countersunk screw into G122-1 chassis

Insert 2 FX088 (5mm thick) over the screw and tight the lower arm G562-11.

Fenix G12-2

If needed, use the provided G562-14 shims to adjust the front ride height.

Front end should look like this.

Take care of the direction for G56-039. The arrow is toward the front of the car.

Secure the G56-030 upper arm mount to the G56-039 using 2 HW004 M3x10mm Hex button screw.

You have to prepare 2 mirror sets.

Install the 2 arm holders using 4 x HW007 M3x8 countersunk screws.

Active caster settings.
0 Degrees are default setting.

G56-031 arm –

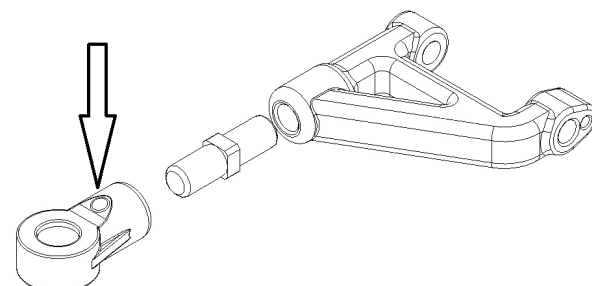
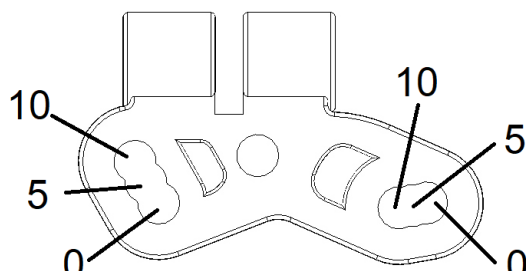
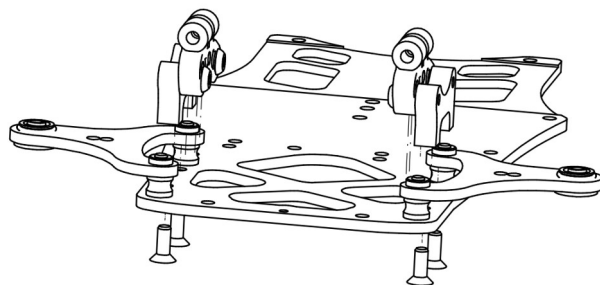
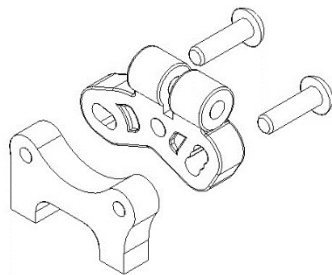
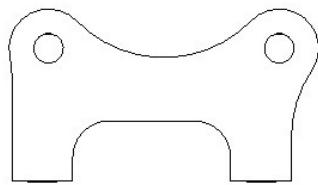
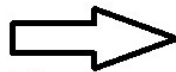
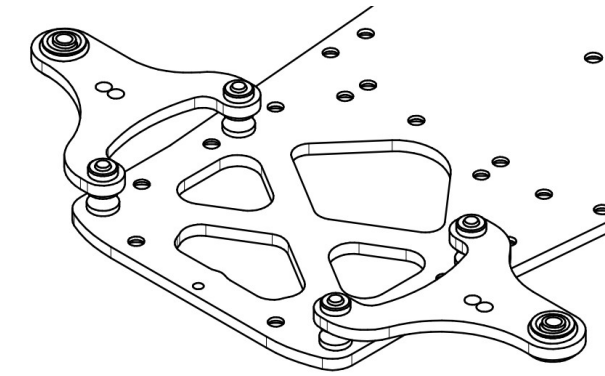

Fenix G12-2

G56-033 eyelet-
G56-032 turnbuckle
G56-037 sphere

Make 2 sets

Note: the dimple is the lower face

Slide the G122-7 front beam into the upper arm mounts, then insert the G56-034 hinge pins and secure them with the HW031 M2x4 screw

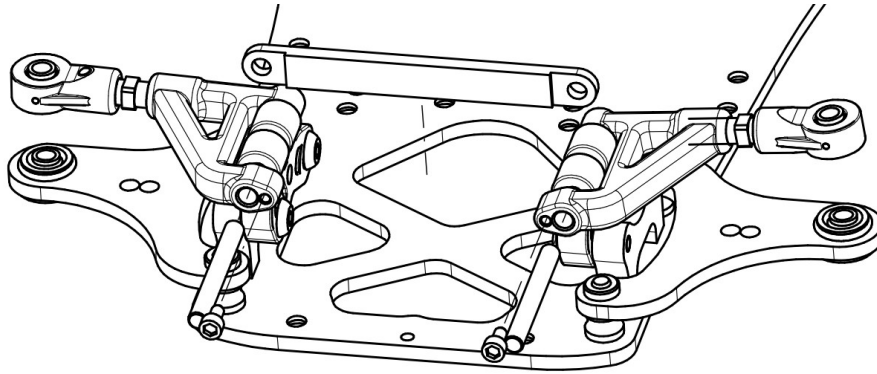

Note: carbon holes are precise, you might want to enlarge them slightly

Steering hub, make 2 sets

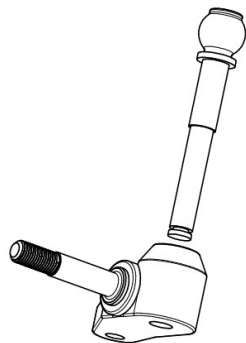
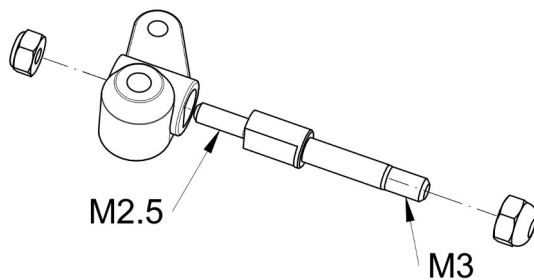

Insert the kingpin into the steering hub.
Thread portion will be a bit tight, you can enlarge a bit the hole with a body reamer and add a drop of oil while treading it into the hub.

Fenix G12-2

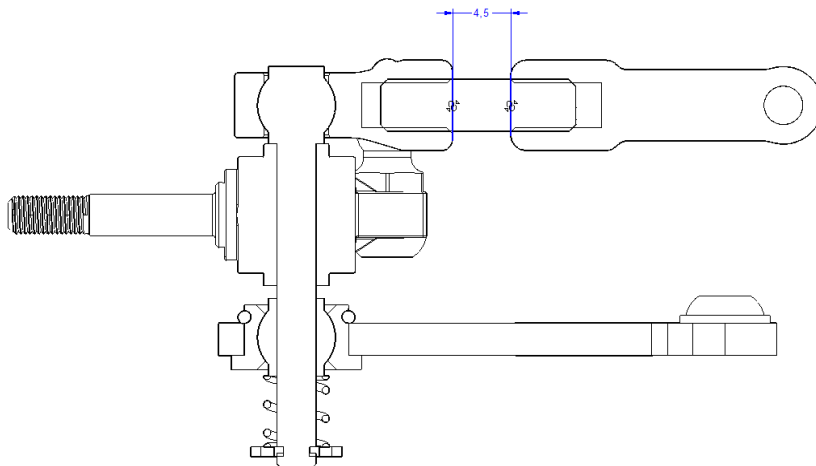

Set the distance at 4.5mm.

The proper camber setting should be set with the car ready to run.

Slide the kingpin and spring as shown, close them with the seeger ring

Assemble the FX0061 ball stud using the HW-003 M3x8 button screw as shown.

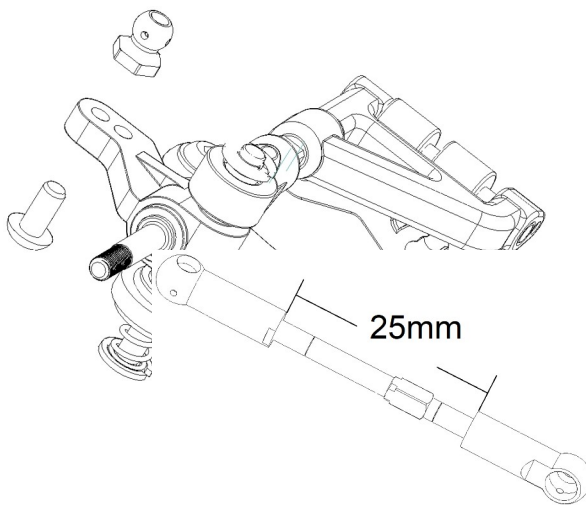

The dimension shown is a starting point, final refinement will be done while setting the model

Make 2 sets

Bag B

Servo Mount

Fenix G12-2

Servo is not included, G12-2 need a Mini servo.

G12-2 can carry the following servos fixed directly on the chassis:

PowerHD M8 Pro
Sanwa PSG HR SXR

To use other servos, you can use the "bridge" provided, following instructions are meant for this situation.

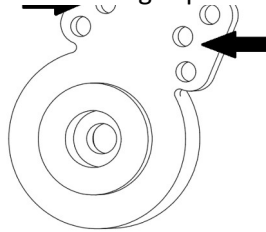

You'll find a Kimbrough servo saver, 25 spline.

Enlarge the highlighted holes at 3mm diameter

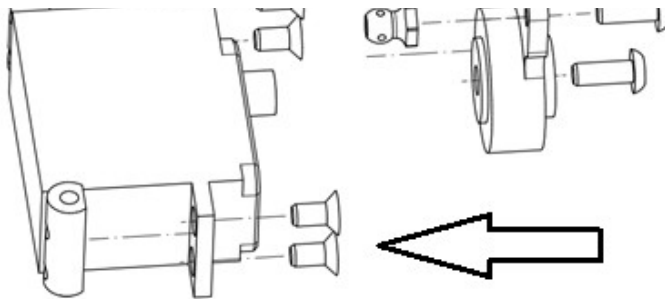

Use the 2 x HW003 M3x8mm button to secure the FX-FU48 to the servo saver.
Use the 4 x HW012 M3x6 countersunk screw to fix the FX022 servo mount

Note: Servo and Ball stud position affect Ackerman angle.
Use it as setup option.

Note: according your servo, you can use just one hole on the servo mount

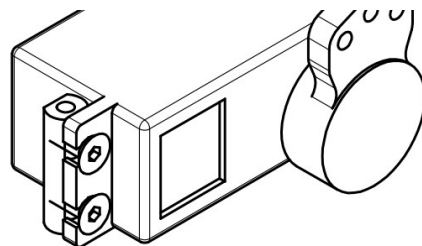

Assembled group.
Servo saver should be vertical when servo is neutral.

Servo saver can be fixed with the 3x10mm screw or the self tapping, according the servo.

Fenix G12-2

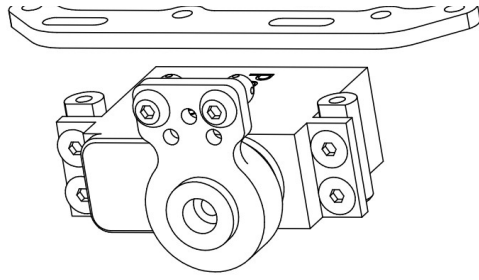

Using 2 x HW008
M3x6 Button, fix the
servo group to the
G12-7 servo holder.

Insert 2 washer under
the M3x6 screws

Take care to centre
the servo saver
toward the servo
holder.

Fix the servo group to
the chassis using
15mm post

Insert the FX0074
3mm shims under the
15mm post

Fix the group to the
chassis with HW007
M3x8 screws

Front end is omitted
for clarity

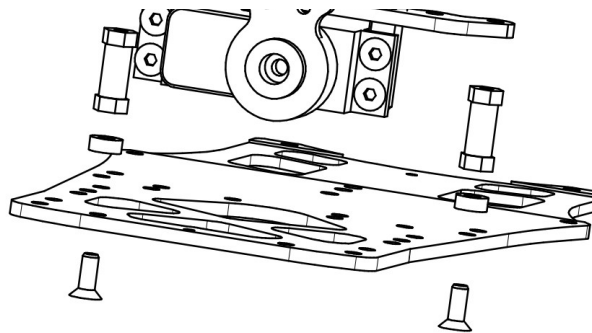

Bag C

NOTE:

Before start to assembly the rear end of G12-2, we strongly suggest you, to visit the Fenix Racing Youtube channel and look the "V-link suspension setup" video.

Just scan the QR code



Motor Pod

Also, in our Youtube
page, you'll find
some cool video
about Fenix Racing.

Fenix G12-2

Using 3 x HW012 M3x6 countersunk screw fix the V-link F2 to the motor pod.

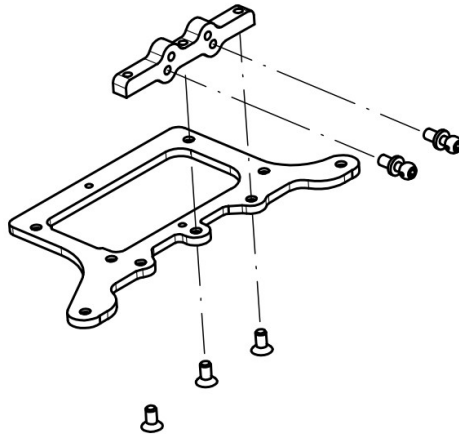

Insert 2 x male ball stud into the V-link F2.

There will be other HW012 M3x6 countersunk screws, you'll use to fix the sphere for the links.

Insert 2 x male ball stud into the V-link F2.

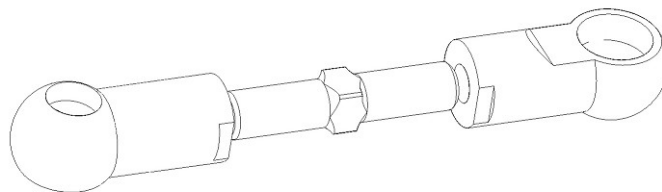
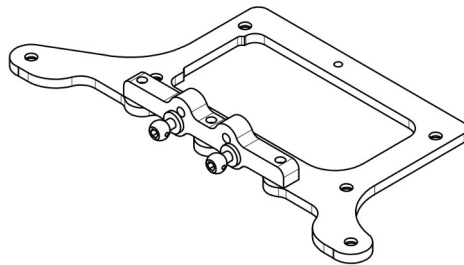

Build 2 set of link using 2 x TR15 and 4 FX0037 - short
Keep this dimensions.
Fix the link over the V-link F2

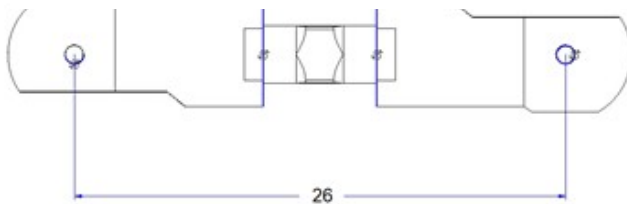

Using 4 x HW012 countersunk screws, fix the motor holder to the motor pod.

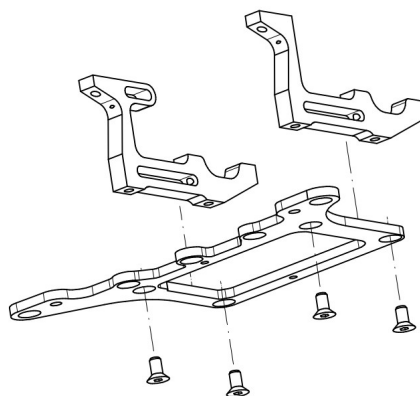

Tight the screws evenly using an "X" pattern

Note: V-Link F2 is omitted for sake of clarity.

Fenix G12-2

Insert the bearing into the G12-C bearing holder.

Note that the mark should be on the same position (vertex NOT important) .

G12-C allow you play with the wheelbase giving +1mm

Fix the G12-C to the bulkheads with 2 HW003 M3x8 button screw in the front holes.

Rear holes, you need to install the G12-10 brace and fix brace and G12-C using HW029 M3x12 button screws.

Tight the screws evenly using an "X" pattern

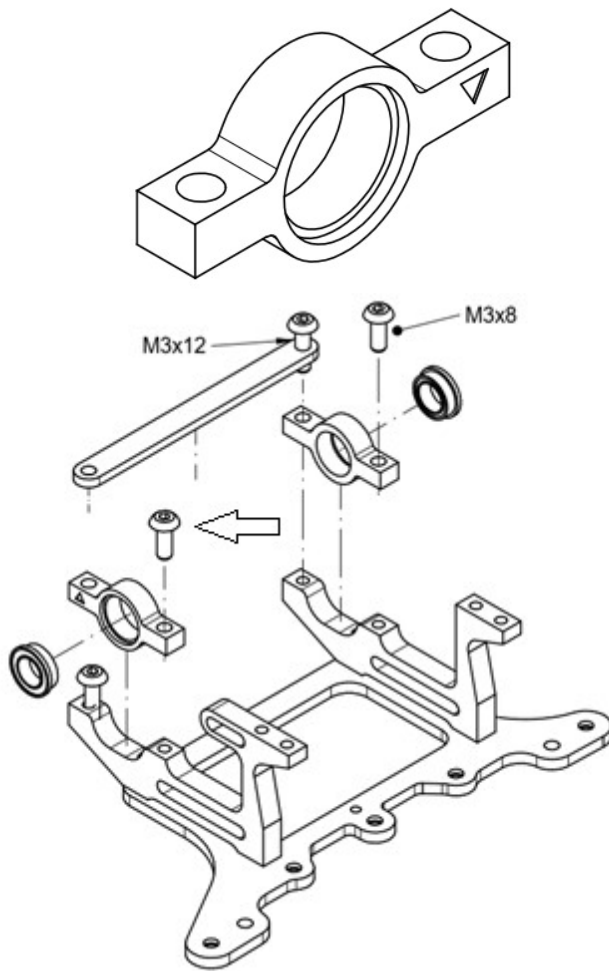

Note: the arrow show a screw that might interfere with some motors/certain gearing. Please check.

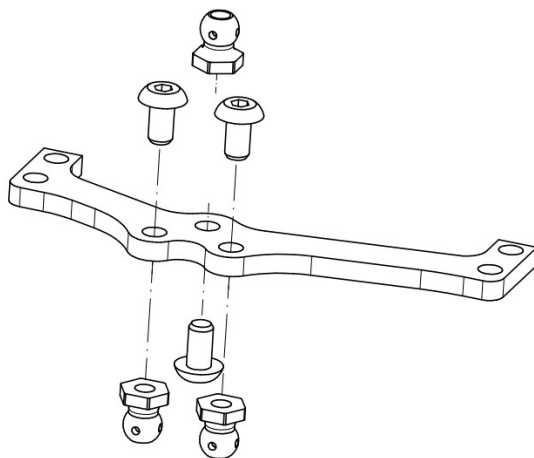

Use the provided HW008 M3x6 button screw to install the ball stud to the shock holder.

Note: Wait to install the shock holder to the motor group.

Fenix G12-2

Note:

Option for the Alu version.

Insert 2 x 0.5mm shims under the link sphere.

Not included in the carbon version

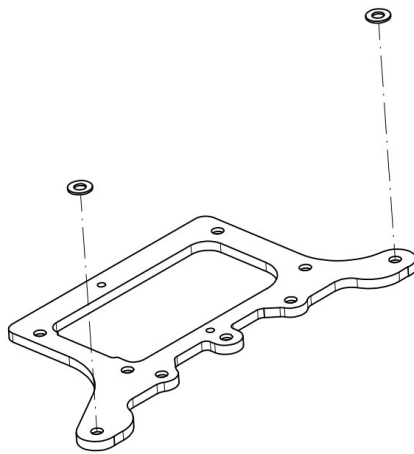

How about a cup of coffee now? You deserve it!

While drinking it, maybe you can also visit our FB pages



Bag D

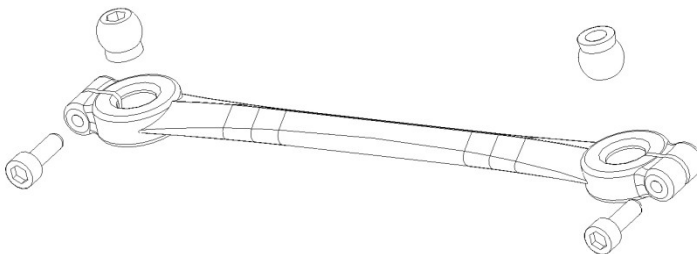

Rear V-link and common parts

Prepare 2 sets – note the position of the spheres.

Use 2 x HW0014 M2x 6 screws and 2 x FX002 spheres each

Fenix G12-2

Grub screw M3 x 8

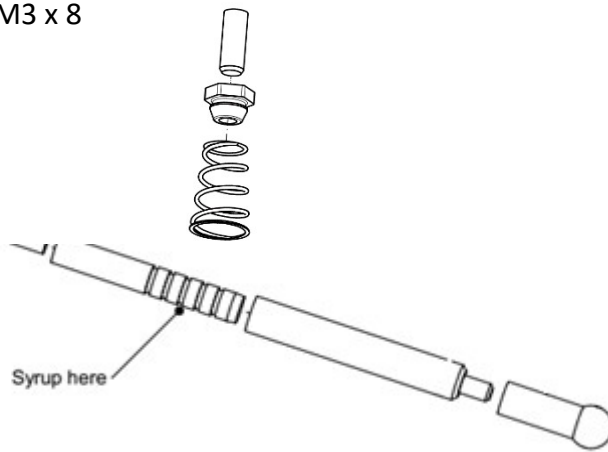

Prepare 2 side spring set as shown.

Assembly the 2 side dampers as shown

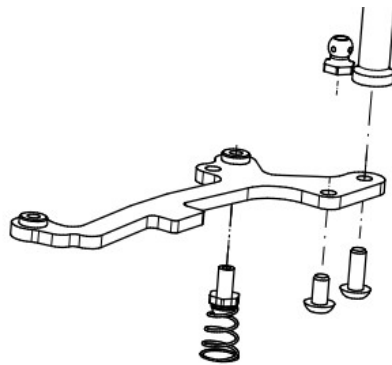

Prepare 2 **mirror** like side element, using G122-3

Fix the body post using 1 HW003 M3x8 button screw.

Fix the FX0061 using 1 HW008 M3x6 button screw.

Insert the side spring group into the carbon fibre

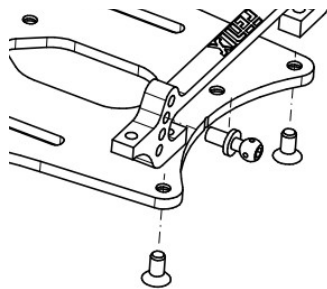

Assembly the M20 V-link1 to the chassis, using 2 x HW012 M3x6 countersunk screw.

Install the FX0061-M in the M20 V-link1 as shown.

Fenix G12-2

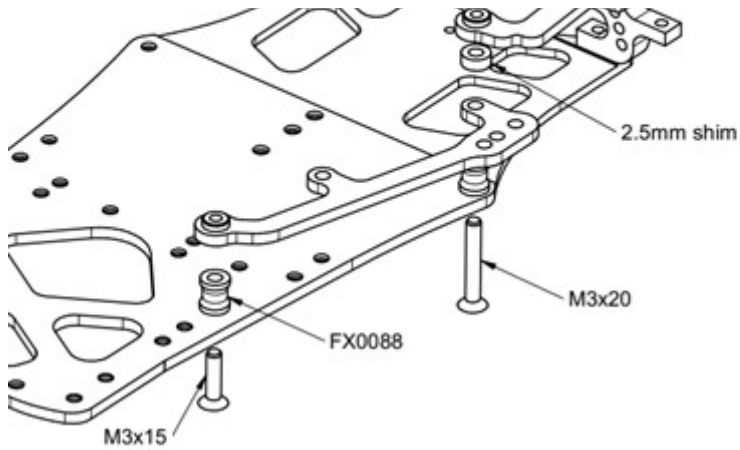

Install the side group as shown using 1 x HW001 M3x20 countersunk screw and 1 HW020 M3x15 countersunk screw.

Make both sides.

Note:
Do not tighten fully the screws

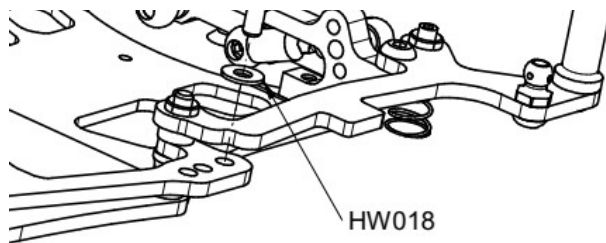

You can insert 1 x HW003 M3x8 button screw plus 1 HW018 M3 washer

Both sides

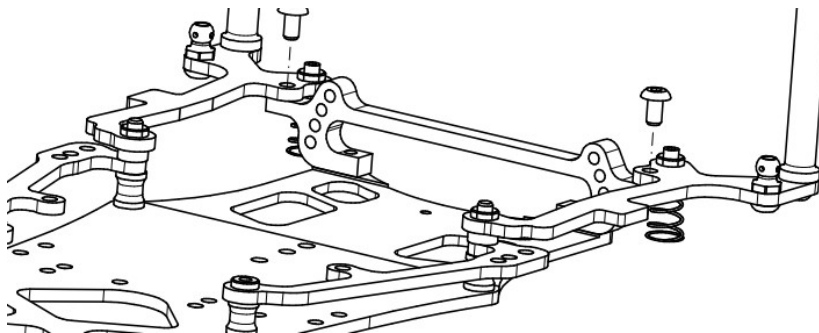

Insert 2 HW008 M3x6 button screw.

Trick!
Do it in on a flat surface, making a light pressure over the chassis

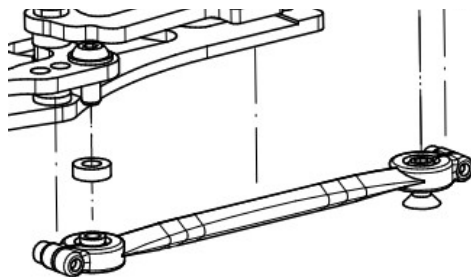

Install the side link you've prepared before.

Insert a 2mm spacer between the carbon side wing and the link.
Use 2 x 2mm allen to tight the sphere link.

Now you can

Fenix G12-2

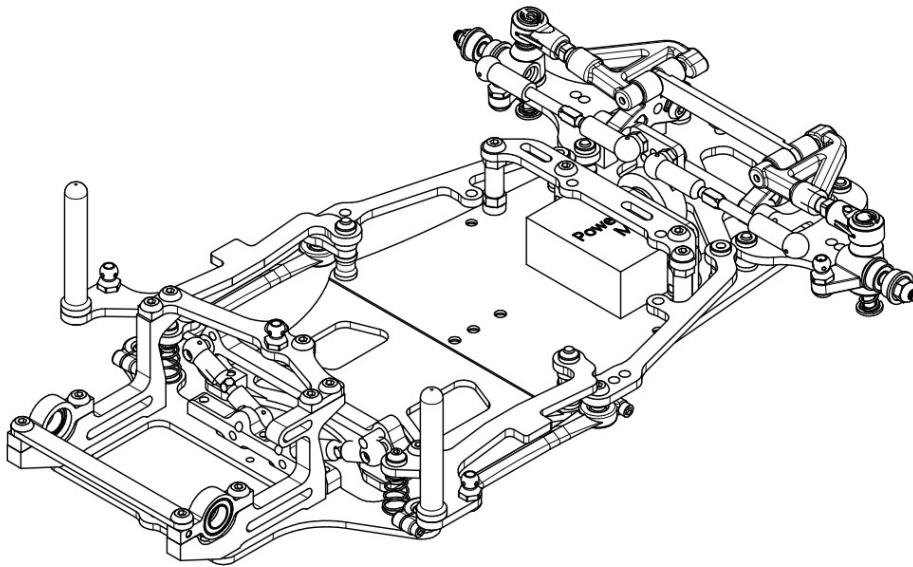

couple the motor pod to the chassis group.

Side links can be installed using 2 x HW012 M3x6.

Now, lay the car on a flat setup board and make the final fine tuning of the links length. Chassis and motor pod must lay flat on the setup board.

Take the proper time for this setting.

Check our channel on Youtube for some explicative video.

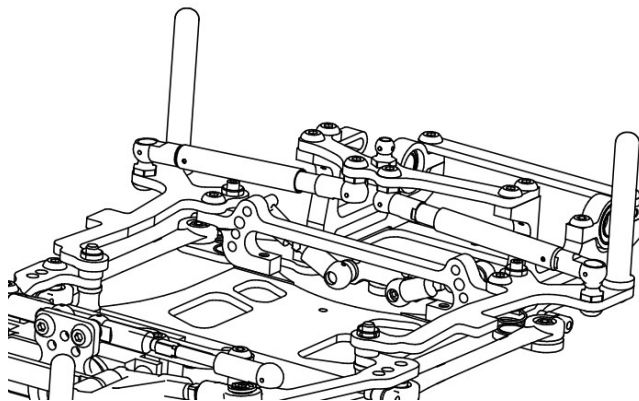

Install the G122-4 shock holder, using 4 by HW008 3x6 button screw

Install now the side dampers

Fenix G12-2

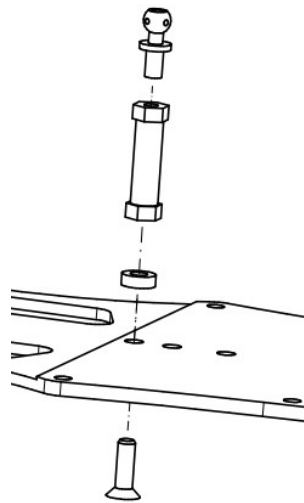

Using an HW033 M3x10 countersunk screw fix the FX0053-20 post. Install the 2mm shim between the post and the chassis. Tight the group firmly. Insert the male stud FX0061-M in the post.

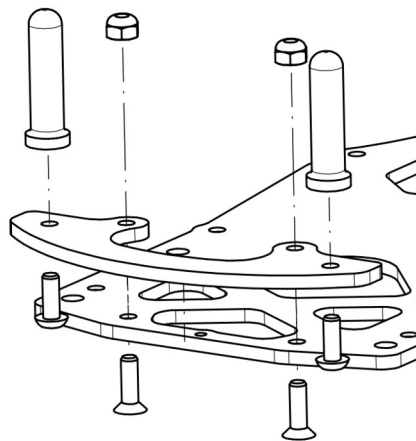

Install the front body post to the bumper using 2 x HW003 M3x8 button screws.

Fix the bumper to the chassis using 2 x HW004 M3 x 10 countersunk screws and M3 Nylocks

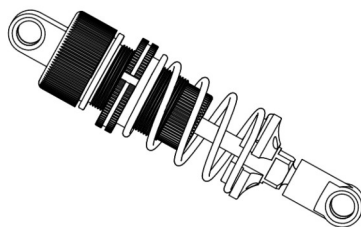

Shock Bag

(soft) Red - Yellow - Blue - White - Black (hard)
2 - 3 - 4 Cylindrical holes * 2- 3 - 4 Conical holes

Springs supplied
Pistons supplied

Fenix G12-2

The M20-K7 shock adjuster will be used to adjust the motor pod droop.

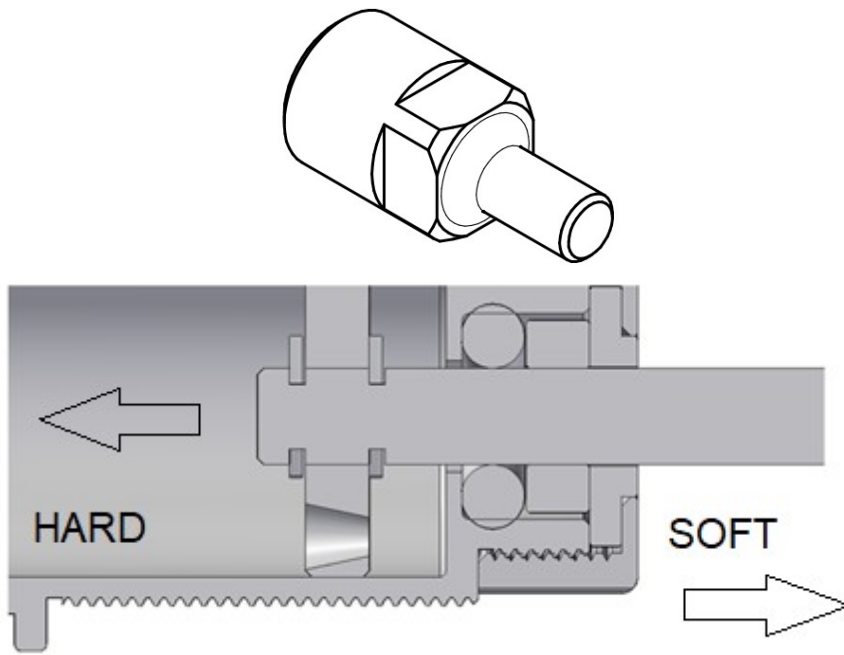

Take care when using conical pistons as shown.

Start assembling the piston . 4 holes .

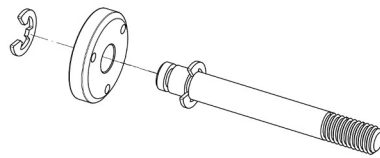

Slide the 3mm shim over the shock shaft.

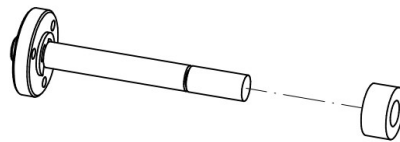

Lubricate and insert the o-ring into the setting ring.

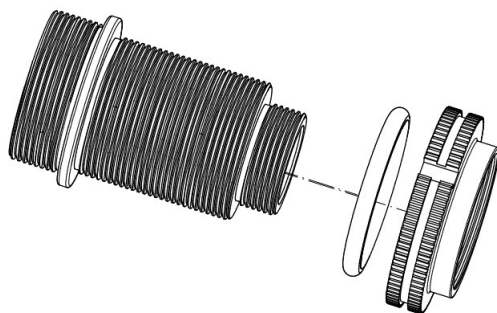

Slide the setting ring over the shock body.

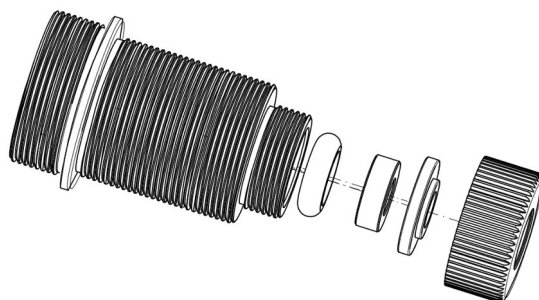

Lubricate the o-ring and guide ring with shock oil or differential grease

Fenix G12-2

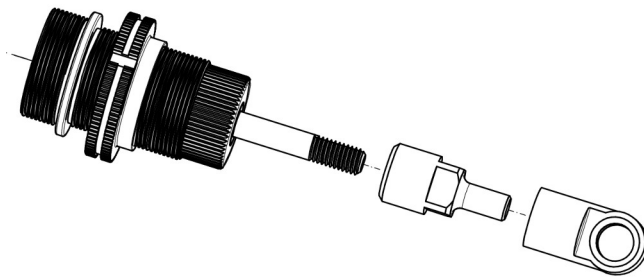

Screw together the G12-K7 droop adjuster and the ball joint (long one)

Fill the shock absorber with your favourite oil...
A good starting point will be #600 with 4 holes

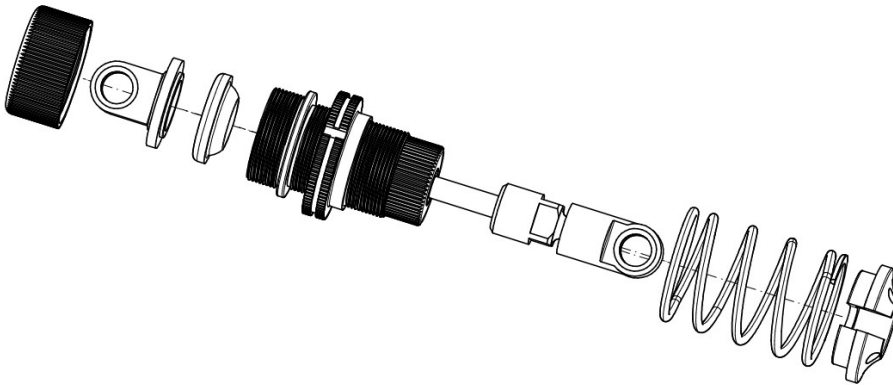

Close the shock absorber with rubber seal, ball joint and cap.

Slide the spring and spring holder in position.

Blue spring is a good starting point.

Spool axle

Fenix G12-2

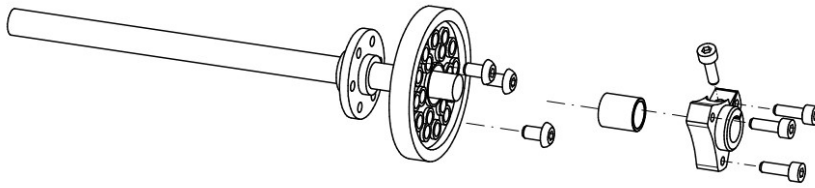

Fix the spur to the spool with the M3x6 screws.

Slide the 8mm spacer and install the drive clamp, fix it with the 2.5mm x 8 screw.

Insert the spool in the motor bulkhead.

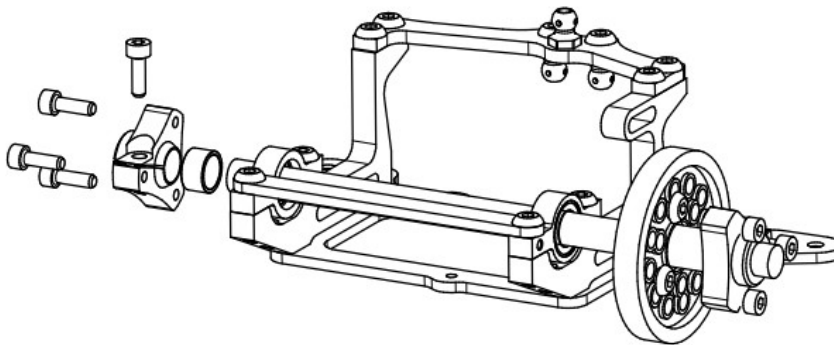

On the left side, slide the FD12-3 4.5mm spacer over the axle, then insert the drive clamp and , fix it with the 2.5mm x 8 screw.

Leave a tiny bit of axial play (0.1/0.2mm)

Tech area

Fenix G12-2

G12-2 represent a major breakthrough in the 1/12 class. Nothing comes close to this 1/12 model.

We've had several drivers developing the car, from Club racers to ETS and Nationals A-main finalist, and we'd like to thank all of them for the time and dedication they put in this project.

Front End: We choose to share the same front end used on G56.2, this allows you to use an easy and proven system that allows you to alter camber, caster and dynamic caster.

Rear End: V-link: we spent quite a lot of time developing this rear end, using different brand of tires, driving on carpet and asphalt.

G12.2 allow several different major setting, according their main chassis

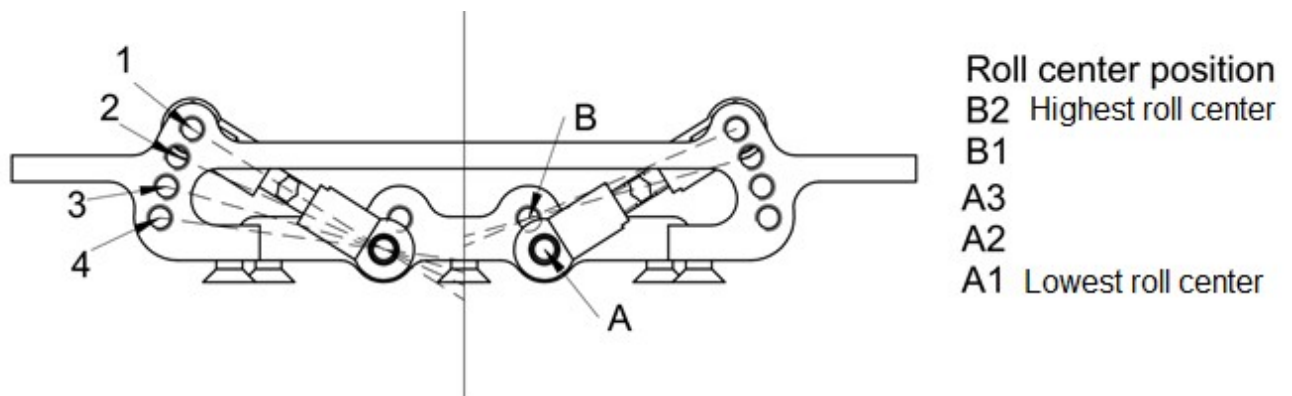

V-Link suspension has the unique ability to alter the roll centre position.

You can alter significantly the amount of rear grip by changing the roll centre position.

B2 is very much like a common pivot rear suspension - A1 give the lowest roll centre.

Most of the time, you'll find a very comfortable setting using A2 or A3 position. Do not set the model in A4

Of course the 2 connection link must have the same length!!!

Here you can see how to set the V-link!



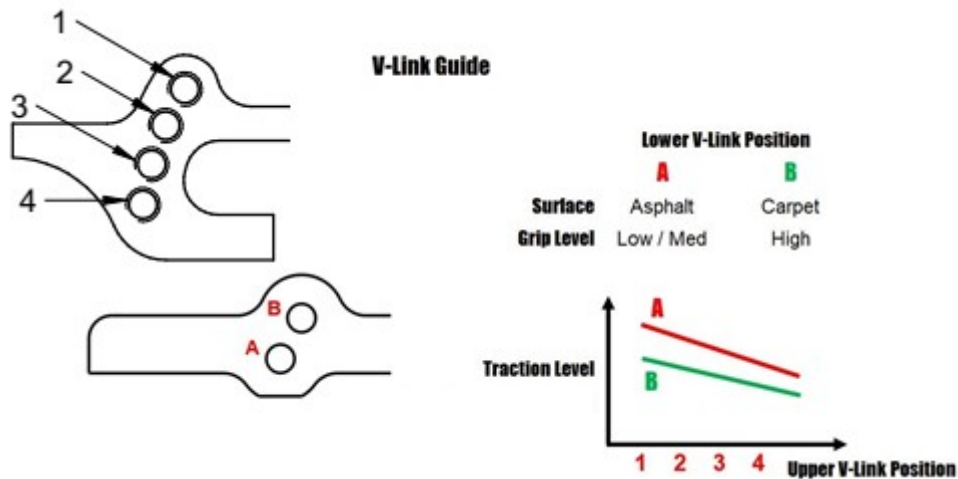

As rule of thumb, low to normal grip = A, normal to high = B

V-link suspension, has the ability to handle a certain degree of self steering, this can be “phased” or “counter phased”

Side link inclination (rear axle bumpsteer, v-link only)

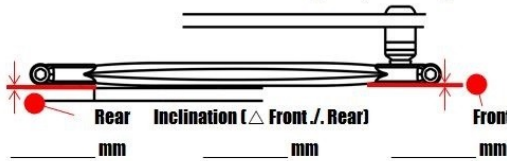

Positive Inclination (front higher)

negative bumpsteer: the outer wheel goes into a toe-out position, hence generating more steering (a tighter turning radius)

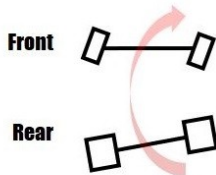

- + increase corner speed under high grip conditions
- + increase mid-corner steering

- loose rear end at corner entry under low grip conditions
- reduced traction at corner exit

Negative Inclination (rear higher)

positive bumpsteer: the outer wheel goes into a toe-in position and stabilizes the rear end

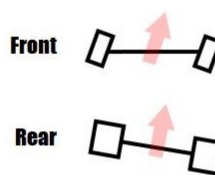

- + increase traction under low- or medium grip conditions
- + avoid snap-oversteer

- car tends to push at corner entry
- reduced on-power steering

Fenix G12-2

Millimetre per revolution aka Rollout

Pancar (1/10 – 1/12) are using foam tires, where ratio need to be adjusted after each run, the system is MM (millimeter) Per Revolution aka Rollout.

It means you want to check how many mm the motor move each revolution.

You need to know:

Diameter of tire (easy take your Vernier and check it...) :

Spur size and Pinion size

Diameter x 3.14 = perimeter

Tire diameter 56 x 3.14 = 175.84mm ok... keep it..

Spur / pinion 81 / 26 = 3.11

$175.84/3.11 = 56.54\text{mm}$ - Each turn of your motor, your car will travel 56.54mm

Rule of thumb: 13.5 – 2S – to timing/blinky mode

Indoor between 50-55mm,

Outdoor between da 65-75,







Huge 1/8 tracks 80mm

Rule of thumb: 4.5 – 2S

Outdoor starting point 45mmpr check temp often during the setup

There are a bunch of free app to be downloaded on your smartphone... Check for instance "Gears", made by Nor-Cal Hobbies, Here you can download "Gears"

<https://play.google.com/store/apps/details?id=com.seamusoft.gears&hl=it>

<i>Stay in touch with us!</i>		
Facebook pages...		
	 Instagram	 Twitter
	 Youtube	
	 Fenix-Racing	 Fenix racing shop